

Inspire architects buildings specifications doors
Inspire the new ideas solid Inspire the rules the fictions resistance emotions
Inspire the sensations Inspire the impressions Inspire the creativity the new
durability Inspire the consultants
Inspire your abilities Inspire the innovations flex styles quality
strong the doors
Inspire the windows efficiency
Inspire the reactions good job
Inspire the emotions reflections
Inspire the rules your limits
Inspire the fictions
Inspire the facades new styles
Inspire the fictions formations
Inspire the future architects
Inspire the uniqueness



Inspire architects buildings specifications the doors
Inspire the new ideas solid Inspire the rules the fictions resistance emotions
Inspire the sensations Inspire the impressions Inspire the creativity the new
durability Inspire the consultants
Inspire your abilities Inspire the innovations flex style
strong the doors
Inspire the windows efficiency str
Inspire the reactions good job
Inspire the emotions reflections
Inspire the rules your limits
Inspire the fictions
Inspire the facades new styles
Inspire the fictions formations
Inspire the future architects
Inspire the uniqueness







AISI 304

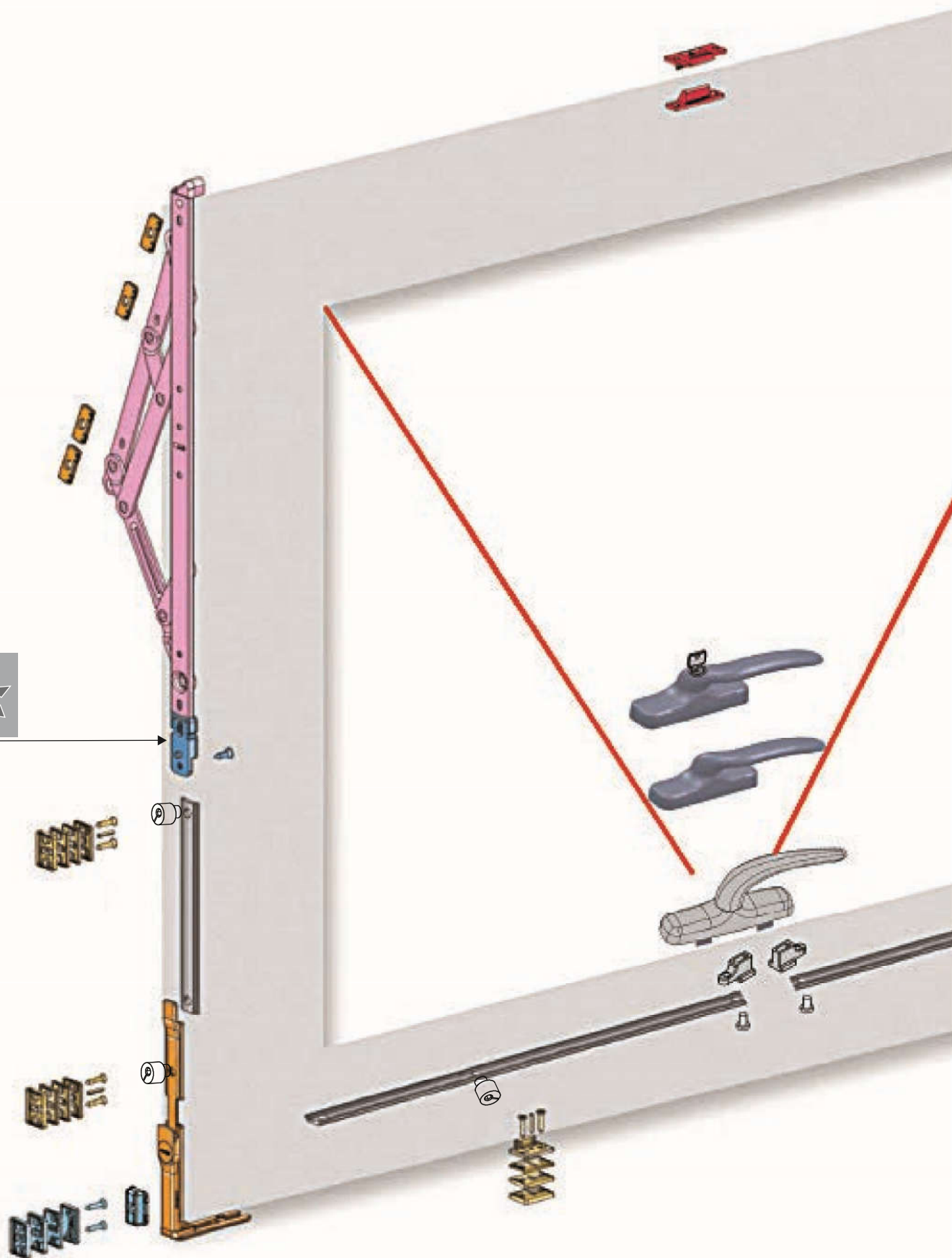

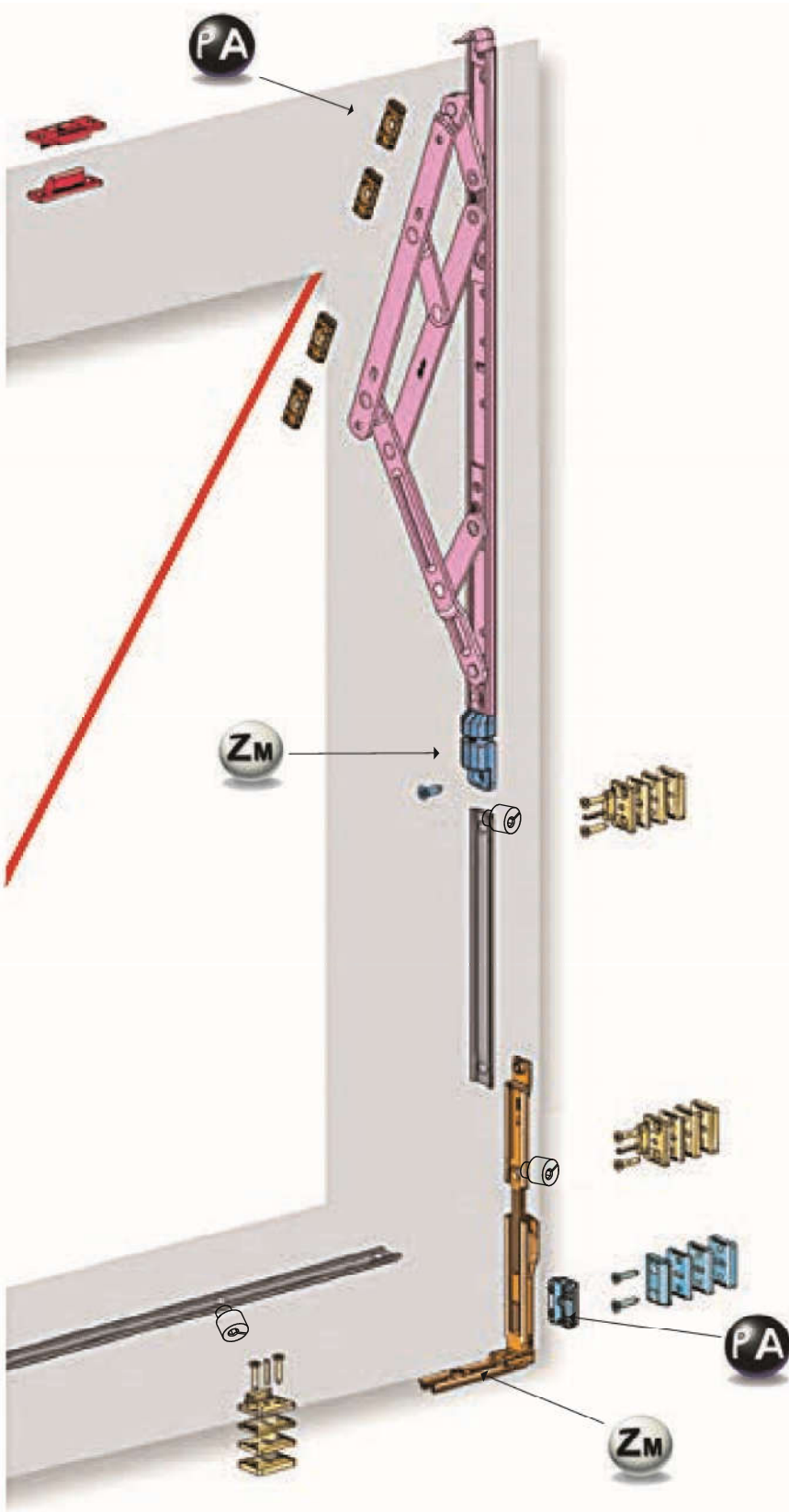

0757Bi Nefer eksenel kol



1009 FILL kıvrık tip cephe kolu



1515B Köşe dönüş elemanı



1596 İspanyolet kilitleme pim

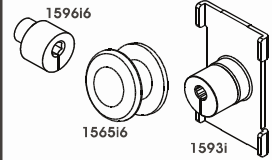

1598C Beslemeli pim karşılığı

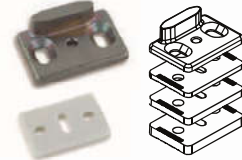

1613 Kasa-kanat destek elemanı



3255 Yükseklik ayar elemanı

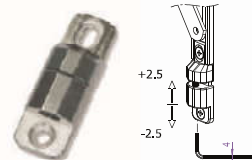

3256 Makas alt besleme

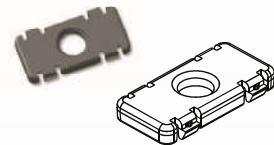

3257 Üst gizli baskı elemanı



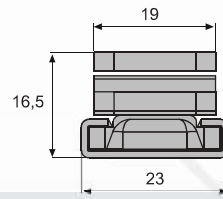
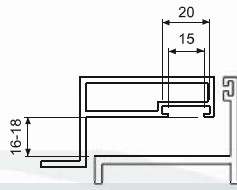
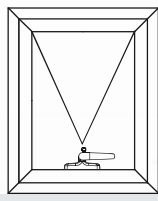

3250

Maud cephe makasları



- Gövdeye bağlı kol sayısı 6'dır. 6 kol sayesinde taşıma kapasitesi rakiplerine göre yüksektir.
- 2 ayrı noktadan frenleme sayesinde kanat yükü gövde boyunca dağıtılır.
- Rüzgara karşı mukavemet maksimumdur.
- Metal kafalar sayesinde kanada tam baskı sağlanır.
- Tüm universal alüminyum profil detaylarına uygundur.
- Tamamen Avrupa standartlarına göre Avrupa da üretilmiştir.
- Uluslararası yeterlilik ve garanti sertifikaları mevcuttur.

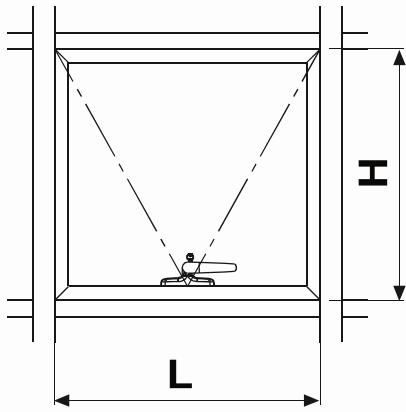

	A	H min/max mm	L max mm	α	W max Kg
3250A	14" 406mm			30°/35°	65
3250B	16" 406mm	800/1200	1400	25°/30°	90
3250C	18" 457mm	1200/1400	1500	25°/30°	100
3250D	20" 511mm	1400/1600	1600	20°/25°	110
3250F	24" 601mm	1600/1800	1800	15°/20°	120
3250H	28" 708mm	1800/2000	2000	15°/20°	130

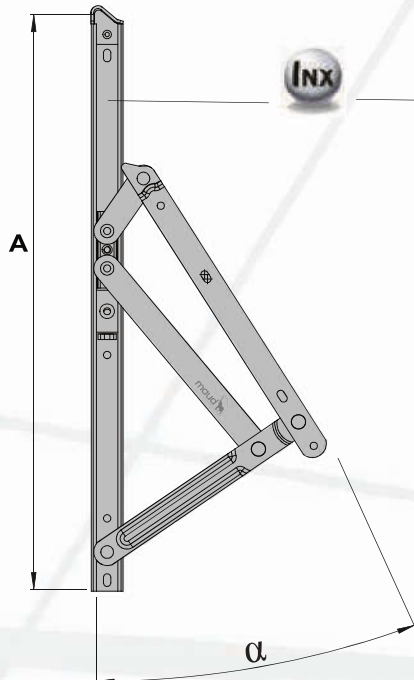
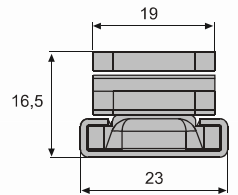
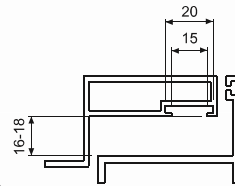
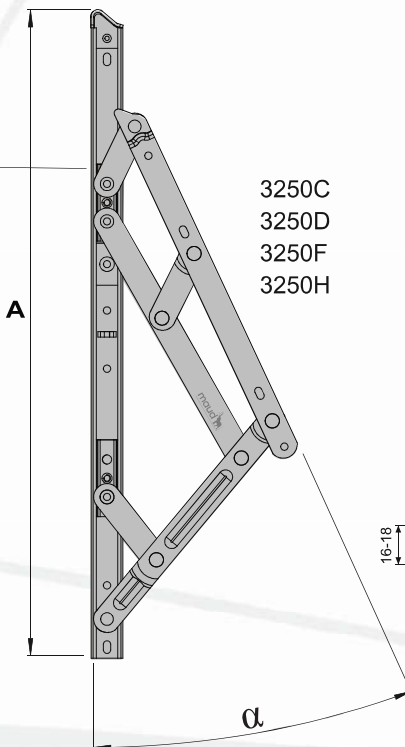
3250A
3250B3250C
3250D
3250F
3250H

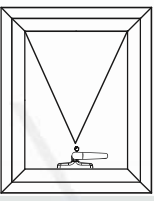

TEST RESULTS

Load test	After applying 220 N per 10", the window keeps operating correctly
Initial assembly measurement	Sample 1 – average measure hinge 1 – horizontal: 29,00 mm – vertical: 20,01 mm
	Sample 1 – average measure hinge 2 – horizontal: 29,14 mm – vertical: 20,21 mm
	Sample 2 – average measure hinge 1 – horizontal: 28,87 mm – vertical: 20,14 mm
	Sample 2 – average measure hinge 2 – horizontal: 29,04 mm – vertical: 19,78 mm
Final assembly measurement	Sample 1 – average measure hinge 1 – horizontal: 29,15 mm – vertical: 20,18 mm
	Sample 1 – average measure hinge 2 – horizontal: 29,27 mm – vertical: 20,29 mm
	Sample 2 – average measure hinge 1 – horizontal: 28,99 mm – vertical: 20,27 mm
Assembly measurements	Sample 2 – average measure hinge 2 – horizontal: 29,14 mm – vertical: 19,96 mm
	The differences between the average measures after and before the durability test are lower than 1,50 mm.
Durability	8.000 cycles without any problem (5 cycles / minute); after the durability test, the window operates correctly

● Statik Test AAMA 904-01 Standardı: Pencere açık pozisyonda yatay ekseninde 220 Newton kuvvetle pencere kapatılır. Bu işlem 10 saniye ara ile tekrarlanır.

● Sayı Testi AAMA 907-05 Standardı: Pencere kapalı pozisyonda yatay ekseninde 110 Newton kuvvet uygulanır. Dakikada 4 defa olmak üzere 8.000 defa işlem tekrarlanır.

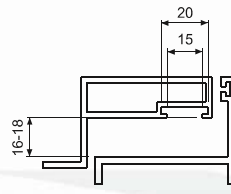
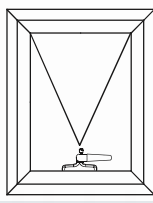
● Materyal üzerine 300 saat boyunca tuz buharı tatbik edilir. Korozyon dayanımı gözlenir.



1009

Maud FiLL kıvrık tip cephe kolu



1009K

Maud FiLL kıvrık tip kiliftenebilir kol



- 3 farklı yerden özel büküm ergonomik tasarım.
- Tamamen Avrupa standartlarına göre Avrupa da üretim.
- Dayanıklı, uzun ömürlü.
- Sağ / sol el kullanımı için farklı modeller.
- İstenen RAL rengine boyama imkanı.
- Universal delik ölçüleri, hızlı montaj.
- Uluslararası yeterlilik ve garanti sertifikaları.

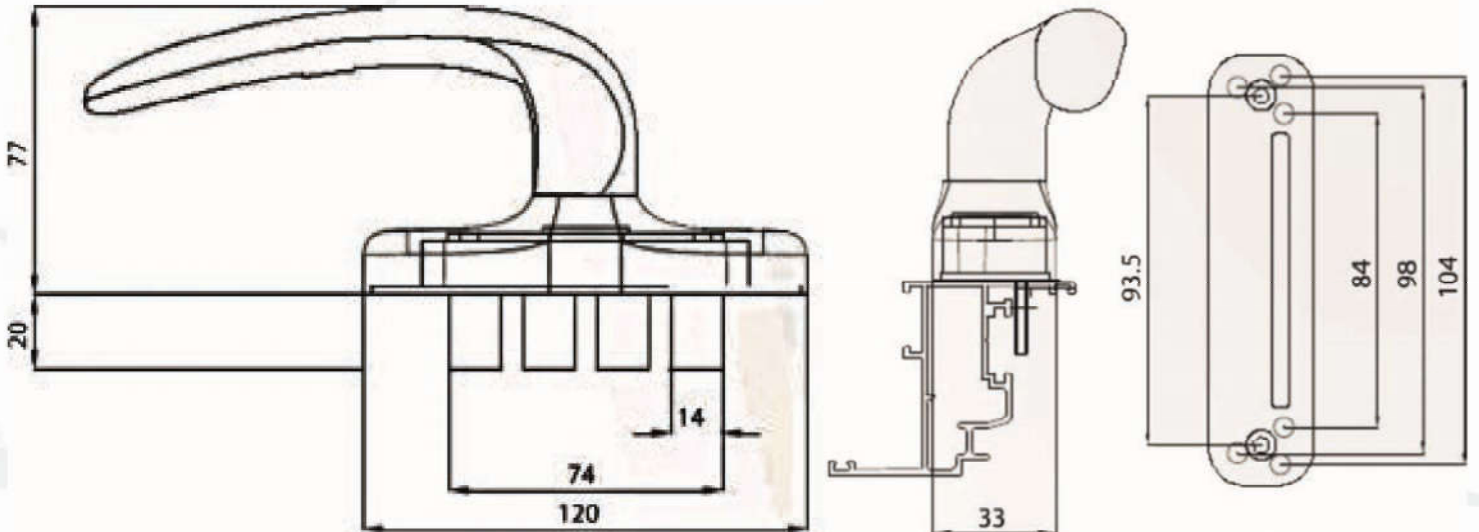
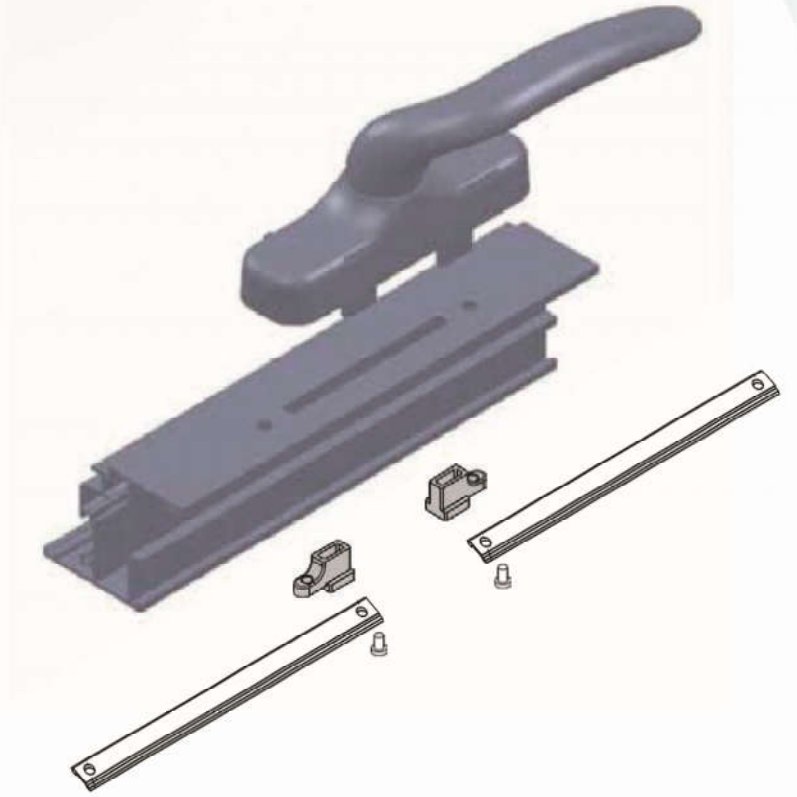

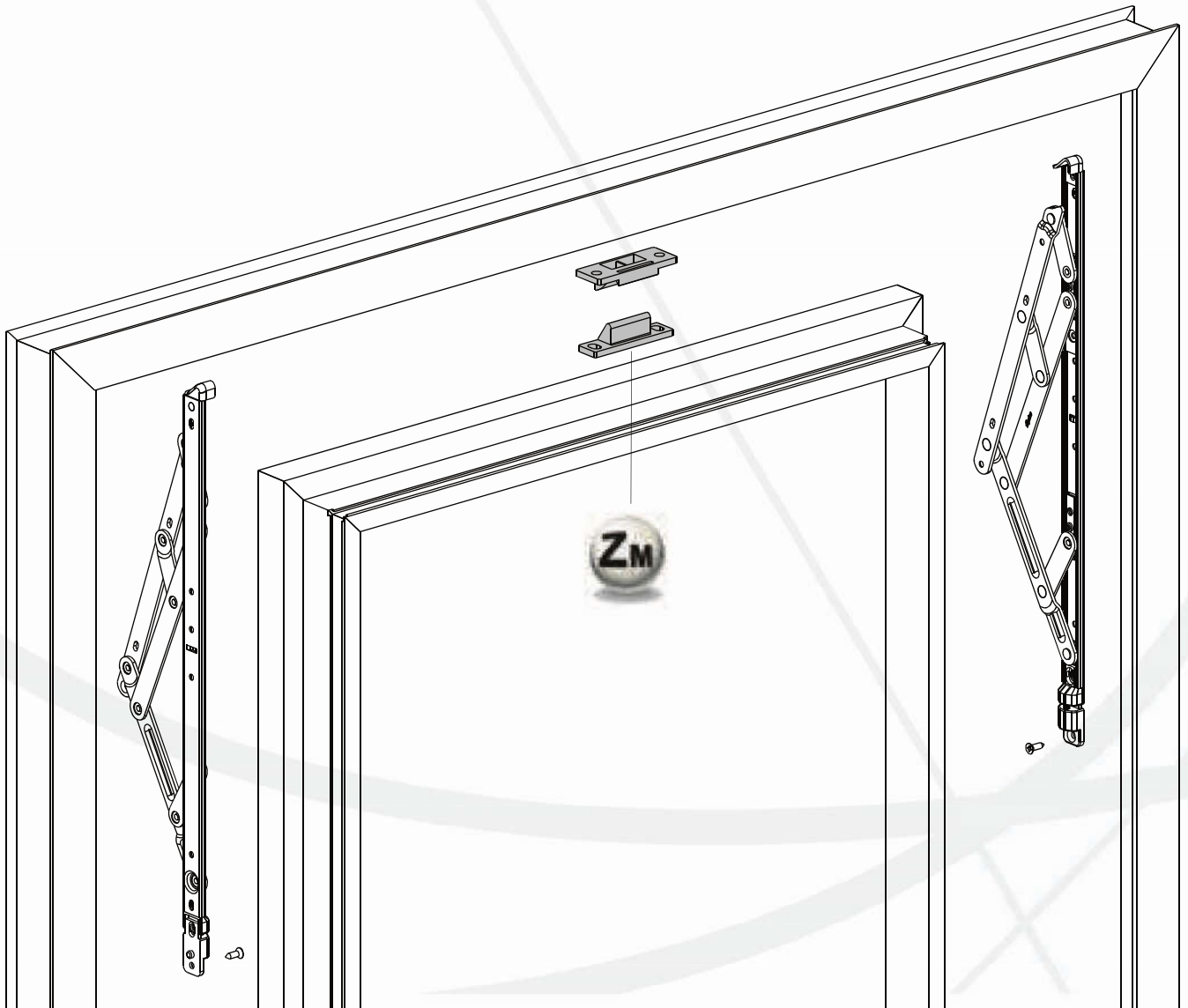
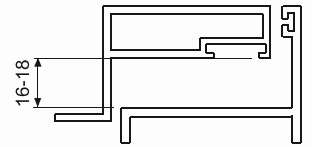
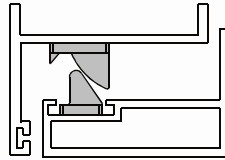
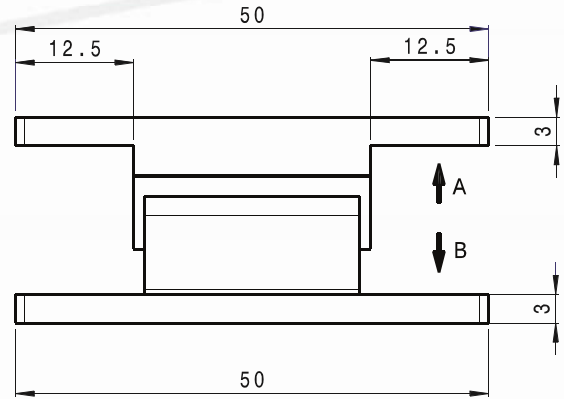
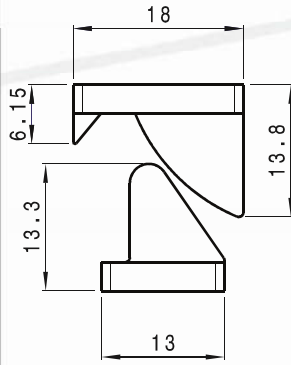
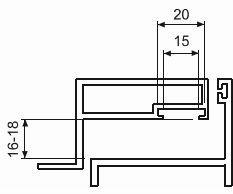
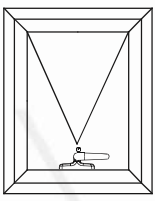

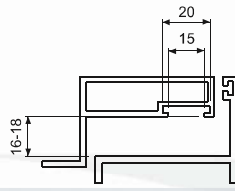
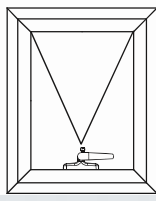

1515B

Köşe dönüş elemanı

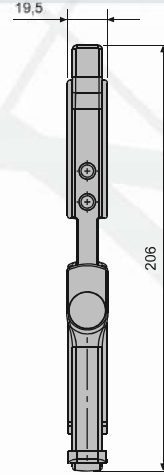
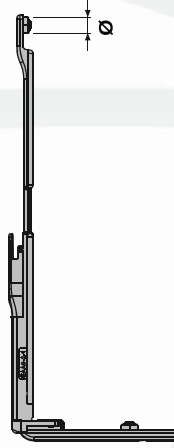

1598C

Maud beslemeli pim karşılığı

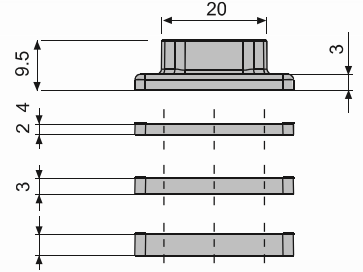
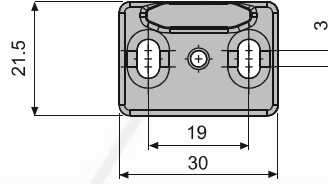

3256

Maud makas alt besleme

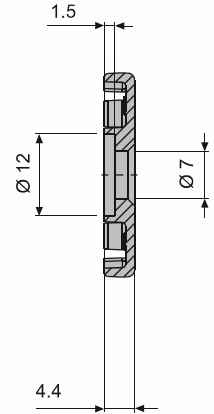
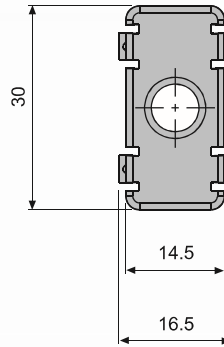

1613

Maud kasa-kanat destek elemanı

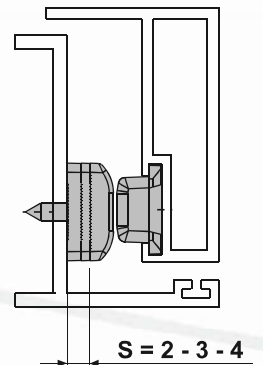
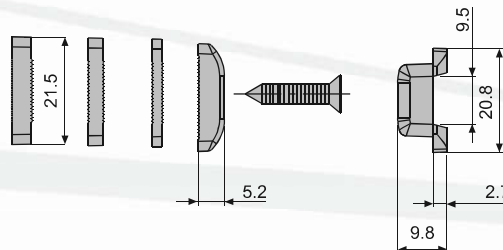
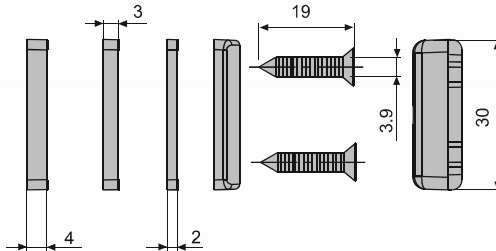

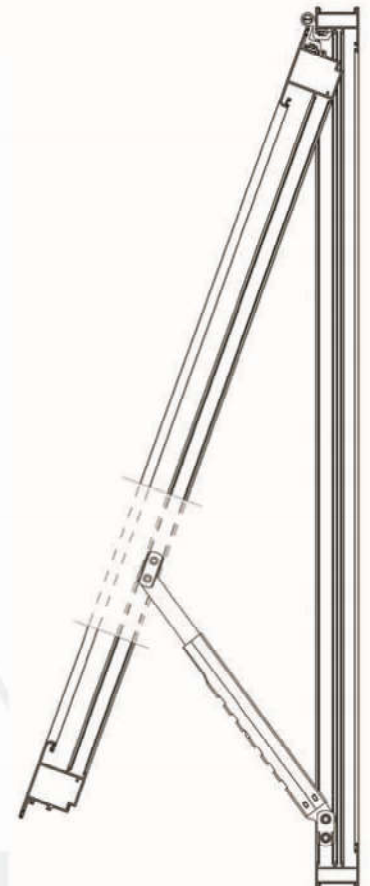
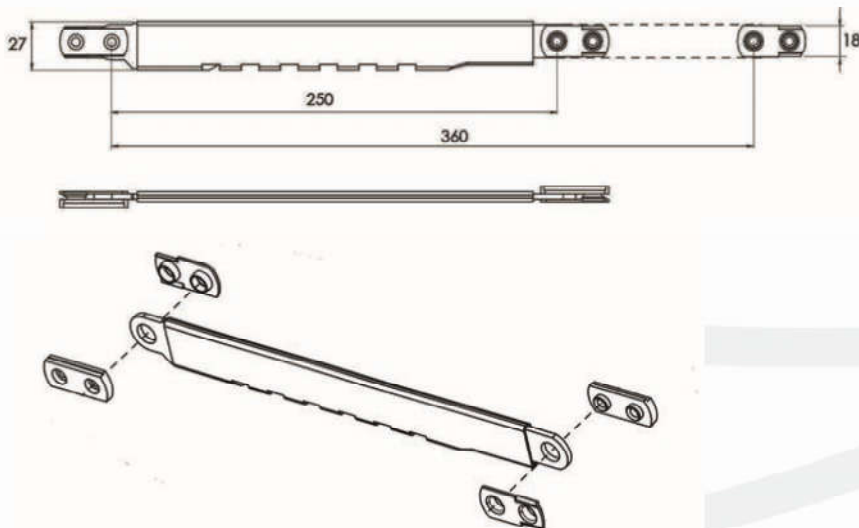
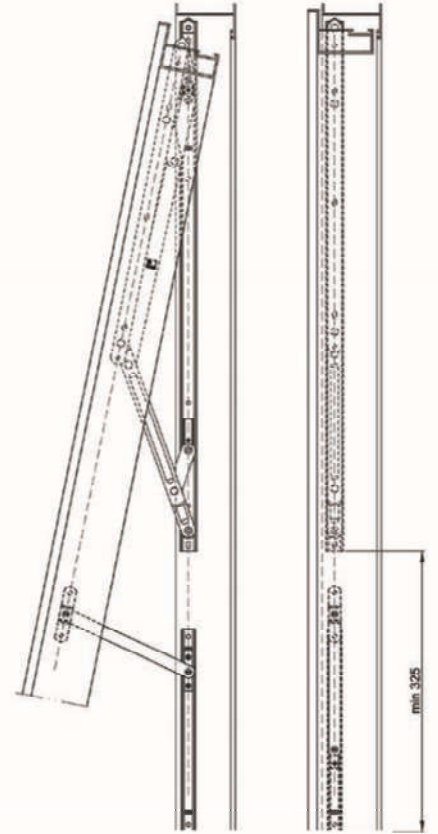
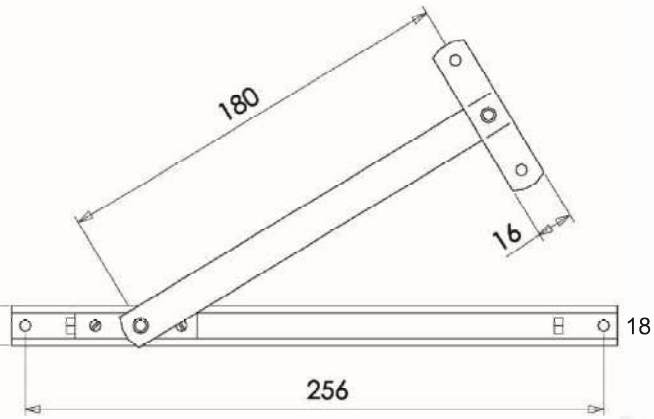
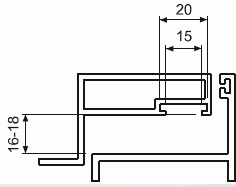
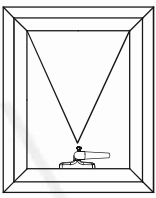

Inspire architects buildings specifications doors
 Inspire the ideas solid Inspire the fictions resistance emotions
 Inspire the sensations Inspire the impressions the creativity new
 Inspire your abilities Inspire the consultants
 Inspire the windows efficiency strong the doors flex styles
 high quality
 Inspire the emotions reflections qualifications
 Inspire the rules your limits the fictions
 Inspire the reactions good job
 Inspire the facades new styles formations heavy duty
 Inspire the fictions Inspire the uniqueness
 Inspire the future



maud aksesuar san. ve tic. ltd. Őti.

Merkez Ofis:
 Adakule,
 Cevizli Mah. Nedret Sk.
 No: 18-22 Kat:16 D:87 34846
 Maltepe | İstanbul | TÜRKİYE
 Tel: +90 216 688 7574 - 73
 Fax: +90 216 688 7572
 info@maud.com.tr

Depo:
 Yedpa Ticaret Merkezi
 Kayışdağı Mah.
 H1 Cad. No: 77
 Ataşehir | İstanbul | TÜRKİYE
 Tel: +90 216 661 6581
 Fax: +90 216 661 6582
 www.maud.com.tr

Inspire architects buildings specifications doors
 Inspire the ideas solid Inspire the fictions resistance emotions
 Inspire the sensations Inspire the impressions the creativity new
 Inspire your abilities Inspire the consultants
 Inspire the windows efficiency strong the doors flex styles
 high quality
 Inspire the emotions reflections qualifications
 Inspire the rules your limits the fictions
 Inspire the reactions good job
 Inspire the facades new styles formations heavy duty
 Inspire the fictions Inspire the uniqueness
 Inspire the future